

MOROOKA EUROPE

HIGH EFFICIENCY IN MOTION



MST80CR

Max. Payload 8T.

**Full Rotating
Rubber crawler carrier**

**CARRIER for SOFT, SANDY and
ROUGH TERRAIN**



360° rotation brings more security, less stress and fatigue to the driver



Easy Control with HST drive system

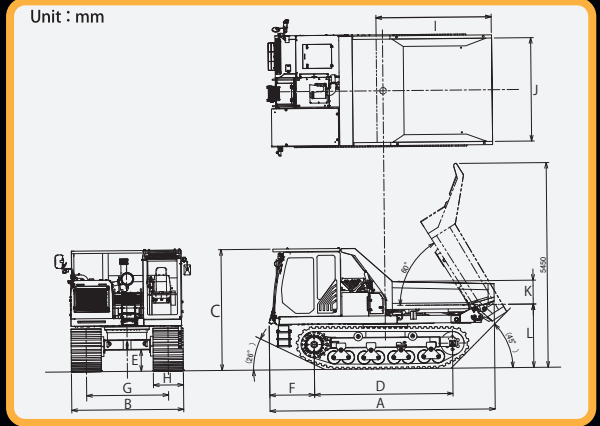

Model		MST80CR							
PERFORMANCE		DUMP BODY				TANK CAPACITY			
Maximum Payload	Kg	8,000	Overall Length	I	mm	2,400	Fuel Tank	ℓ	210
Loading Capacity (Struck/Heaped)	m ³	2.43/4	Overall Width	J	mm	2,350	Hydraulic Tank	ℓ	106
Speed1 Low	Km/h	7.38	Overall Height	K	mm	545	DEF Tank	ℓ	40
Speed2 High	Km/h	10.6	Ground Clearance	L	mm	1,585	DRIVE SYSTEM		
Ground Pressure(empty)	kPa	27.9	ENGINE				HST		
Ground Pressure(Loaded)	kPa	46.6	Model	KUBOTA V5009 Tier 4 final Stage 5			GRADEABILITY		
MACHINE DIMENSION				Nominal Output/rpm	HP(kw)/rpm	206.5(151.9)/2,200	Fully loaded: 27 % (15 degree) Continuous		
Machine Weight	Kg	11,950	Torque	N.m/min-1	883/1,500	OTHER			
Overall Length	A	mm	5,750	HYDRAULIC PUMP				Cabin (ROPS/FOPS) Air Conditioning Joystick control Hardox Dump Body Auto Deceleration Rear Camera Side Camera Radio	
Overall Width	B	mm	2,665	Main Pump		2x variable displacement axial piston pump			
Overall Height	C	mm	3,100	Pilot pump		1x gear pump			
Wheelbase	D	mm	3,890	HYDRAULIC MOTOR					
Min. Ground Clearance	E	mm	560	Travel Motor		2x variable displacement axial piston motors			
Front Overhang	F	mm	955	Swing Motor		1x axial piston motor			
Crawler Distance	G	mm	1,800						
Crawler Width	H	mm	700						
Crawler Size		mm	700x 100x 98						

Remarks: Specification may be changed without any notice.

MOROOKA EUROPE

Im Neugrund 14
64521 Gross-Gerau, Germany
Tel: +49 (0)61529778-0
Fax: +49 (0)61529778-15
Web: www.morookaeurope.com

Contact