

MOROOKA EUROPE

HIGH EFFICIENCY IN MOTION



MST110C

Max. Payload 11T.

Rubber Crawler Carrier

**CARRIER for SOFT, SANDY and
ROUGH TERRAIN**



Long and wide rubber crawler to provide low ground pressure as well as stability and excellent traction



Easy Control with HST drive system

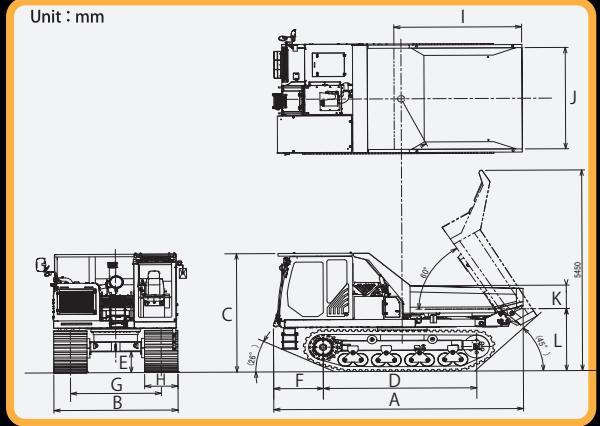

Model		MST110C							
PERFORMANCE		DUMP BODY				TANK CAPACITY			
Maximum Payload	Kg	11,000	Overall Length	I	mm	3,590	Fuel Tank	ℓ	266
Loading Capacity (Struck/Heaped)	m ³	3.42/5.79	Overall Width	J	mm	2,440	Hydraulic Tank	ℓ	125
Speed1 Low	Km/h	7.5	Overall Height	K	mm	390	DEF Tank	ℓ	33.54
Speed2 High	Km/h	10.5	Ground Clearance	L	mm	1,440	DRIVE SYSTEM		
Ground Pressure(empty)	kPa	33.5	ENGINE				HST		
Ground Pressure(Loaded)	kPa	59.5	Model	Cummins QSB6.7-4E Tier 4 final Stage 5			GRADEABILITY		
MACHINE DIMENSION				Nominal Output/rpm	HP(kw)/rpm	252,9(186)/2,000	Fully loaded: 36 % (20 degree) Continuous		
Machine Weight	Kg	14,200	Torque	N.m/min-1	1,152/1,500	OTHER			
Overall Length	A	mm	6,420	HYDRAULIC PUMP				Cabin (ROPS/FOPS) Air conditioning Joystick control Hardox Dump Body Radio	
Overall Width	B	mm	2,850	Main Pump		2x variable displacement axial piston pump			
Overall Height	C	mm	3,160	Pilot pump		1x gear pump			
Wheelbase	D	mm	3,790	HYDRAULIC MOTOR					
Min. Ground Clearance	E	mm	480	Travel Motor		2x Constant displacement axial piston motors			
Front Overhang	F	mm	1,510						
Crawler Distance	G	mm	2,050						
Crawler Width	H	mm	750						
Crawler Size		mm	750x 150x 66						

Remarks: Specification may be changed without any notice.

MOROOKA EUROPE

Im Neugrund 14
64521 Gross-Gerau, Germany
Tel: +49 (0)61529778-0
Fax: +49 (0)61529778-15
Web: www.morookaeurope.com

Contact